

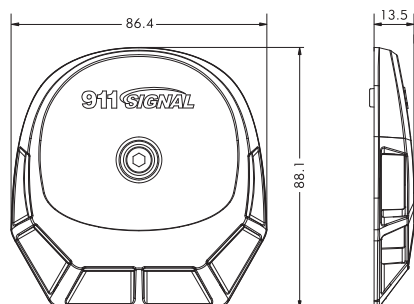

## BEAR

### Features

- > The warning light is designed with a special attention to tail lift safety and is equipped with six light sources (LED) that flash both backwards and to the side. This ensures the security in the area of the platform. The light sources are offset 270° and constructed photometrically identical so that the light can be mounted on a tail lift left or right. The product is ultra-low profile and has an optimized slope design;
- > Cover made of zinc die casting with reflector design;
- > The warning lights blink automatically to the unfolding of lifting platform;
- > Water and dust proof to IP67 and IPx9K



Item	Color	Voltage	Max Power	Lens	LED	Flash Patterns	Mount	Certification
24001	●	DC 12-33V	23W	Reflex	6Pcs 1.5W	12	Screw Mount	EMC R10 ECE R6

### Applications

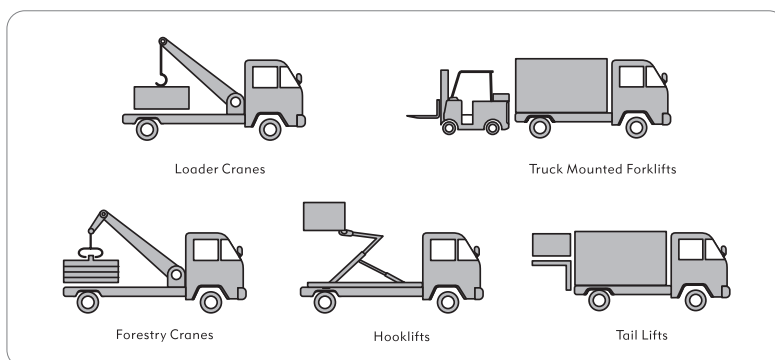

### 911 Signal Technology Inc.

China Office

Tel: +86-574-89017911

Fax: +86-574-82822560

Email: sales@911signal.com

France Office

Tel: +33(0)659163209

Email: euoffice@911signalgroup.com

www.911signal.com

